

SMART PILFER PROOF PAGE/PRIVATE PA SYSTEM.(MODEL WMHF-I)

SMART PILFER PROOF PAGE/PRIVATE SYSTEM provides paging and private Talkback facilities, two important plant communication functions in one reliable, easy to install, maintain & simple to operate unit. Through the page function individuals can be contacted anywhere in the plant. For further communication, the Private talkback line allows two or more people to talk without being heard over the loud speakers.

SMART PILFER PROOF PAGE/PRIVATE SYSTEM is based on distributed amplifier design concept. Each indoor/outdoor wall station contains a Single PCB for driving speakers. This configuration offers a major advantage: when any set is removed, only the associated speaker is inoperable; all other units in the system will continue to broadcast page. All stations are connected in parallel loop and systems may be expanded by extending signal cable from nearest page / private unit.



Operation is simple: When the set goes to paging mode. Speaking directly into the mic, the user announces his page. The responding individual goes to the nearest **SMART PILFER PROOF PAGE/PRIVATE UNIT** and uses PTT button for communication.

OPERATIONS: -

- Page from any of the nearest station.
- All other set gets automatically activated & goes to paging mode.
- Whatever is said in the MIC of the paging PHONE is announced over the loudspeaker of all other Phone's.
- The responding individual goes to the nearest station. Uses PTT button to deactivate all other loudspeakers
- Both the sets can now communicate by using PTT SWITCH.

VERSATILE APPLICATIONS: -

* Cement Plants.. * Mines. * Petrochemical Refineries. * Chemical Plants. * Construction Sites. * Steel Plants. * Spinning Yarns * Fertilizer Plants. * Sugar Mills. * Power Generation Facilities * Pulp & Paper Mills * Food Processing Plant * Warehouses * Ammonia Storage Area * Recreation Facilities * Hydroelectric Facilities * Drilling Rigs * Ammonia Storage Area * Process industries * ANY LARGE AND MEDIUM SCALE INDUSTRIAL UNITS.

SMART CHOICE: -

- **UN LIMITED NO. OF PAGE/PRIVATE UNITS CAN BE CONNECTED IN PARALLEL LOOP.**
- 16-gauge enclosure with powder coat finish.
- Internal amplifier for internal speaker on the DIAL.
- PTT switch for press to talk and release to listen communication.
- Noise canceling dynamic mic.
- A service temperature range from 0 to +60 C.
- Encapsulated circuit boards impervious to water and condensation.
- Single PCB design for plug & play operation.
- Easy troubleshooting ensuring minimum downtime.

SYSTEM CONFIGURATION

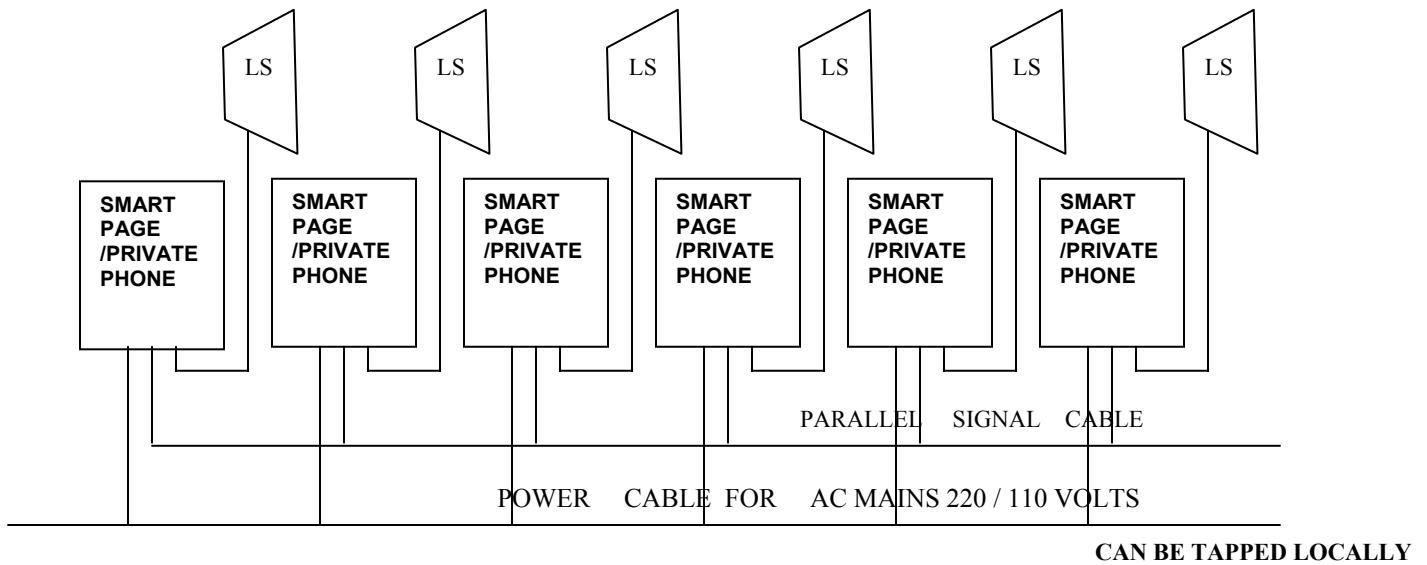

SMART CONSTRUCTION:-

The Field units are Integrated canopy design with weatherproof construction made of 16 SWG steel body duly powder coated to withstand high temperature and humid working atmosphere. Internal Speaker is provided with robust PTT switch on the front Plate.

SMART CABLE:-

NON SPECIALITY NON CRITICAL CABLES

- 1.5 sq mm cable in parallel loop for the SMART PAGE / PRIVATE UNIT.
- 1.5 sq mm 3 core POWER cable for EACH SMART PAGE / PRIVATE UNIT.
- 0.75 mm, 2 core, flexible cable for LOUDSPEAKERS

SPECIFICATIONS: -

Electrical Requirement: -

Power consumption	< 35 Watts.
Stand by consumption	< 5 Watts.
Amplifier	30 Watts (RMS).
Horn Speaker	60 Watts, 8 Ohms.
Internal Amplifier	.500 Watts(RMS).
Internal Speaker	3 Watts , 8 Ohms.
Insulation	600 V for 3 min between power source & parallel line.

Mechanical Specifications: -

Dimensions	360 X 160 X 180 (in mm).
Weight	5 Kgs.
Construction	16 gauge Powder Coated Steel Body.
Standard mounting	Vertical wall / panel.
Microphone	Noise canceling dynamic.

Environmental: -

Moisture Resistance	0 to 95% humidity with PCB conformal coated.
Temperature Range	0 to +60C.
Dust resistance	Fully weatherproof enclosure.

CONFIRMING TO IP 65-DEGREE PROTECTION.

INDUSTRIAL COMMUNICATIONS SIMPLIFIED .

Cables & Wireless Co.

FF 75 RAJAT ARCADE, MIDC T-POINT,
AMRAWATI ROAD, WADI,
NAGPUR – 440023.

PHONE:-07104-321913,07104-224381.

Fax:- 07104-224381.

Cell: - 098226 95746, 09225227945, 09822941190.

Website:- www.cnwcom.in. E-mail: - cnwcom@gmail.com.

“(Specifications and description subjected to change without prior notice)”